

## 外形図 External Diagram

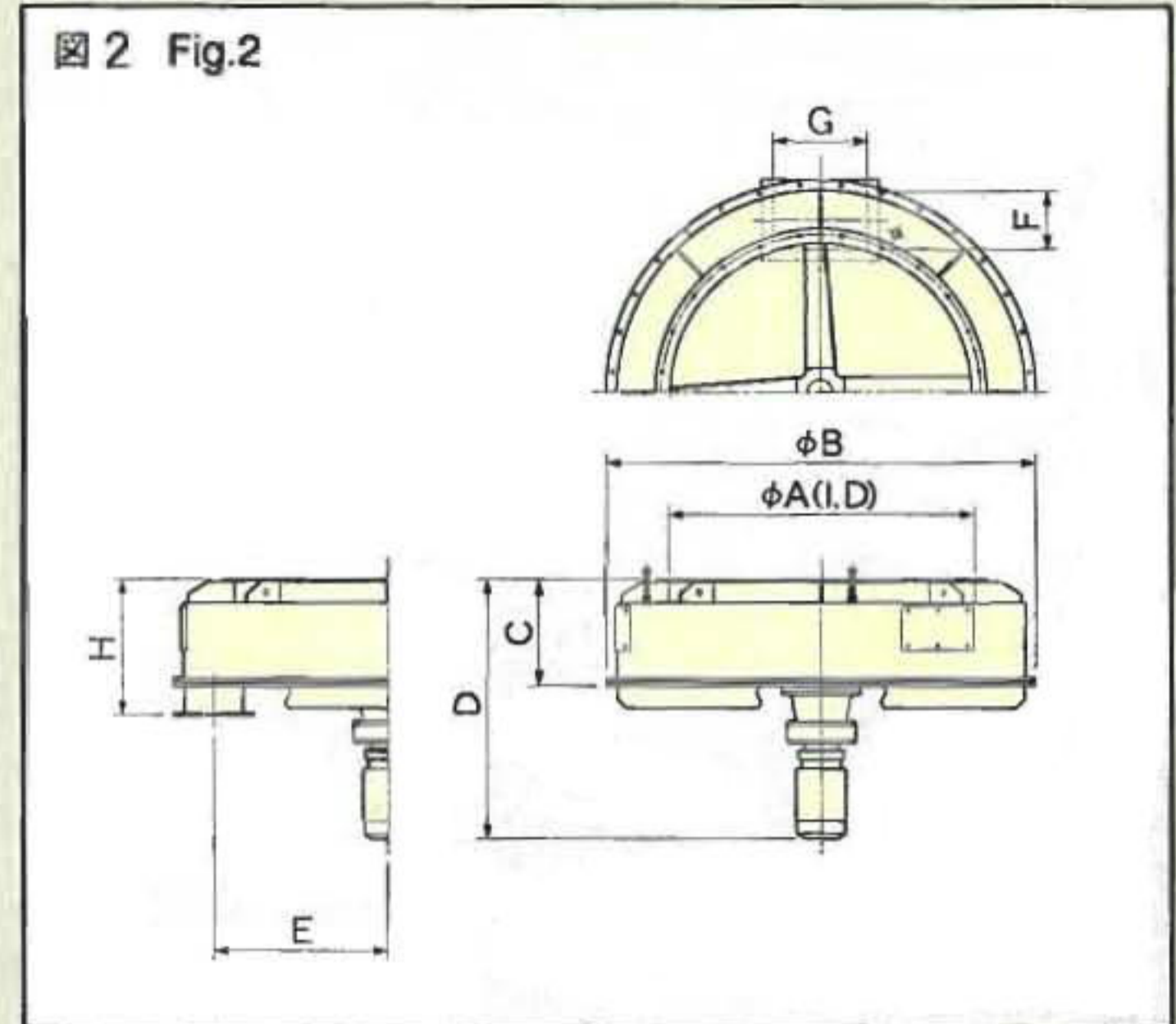
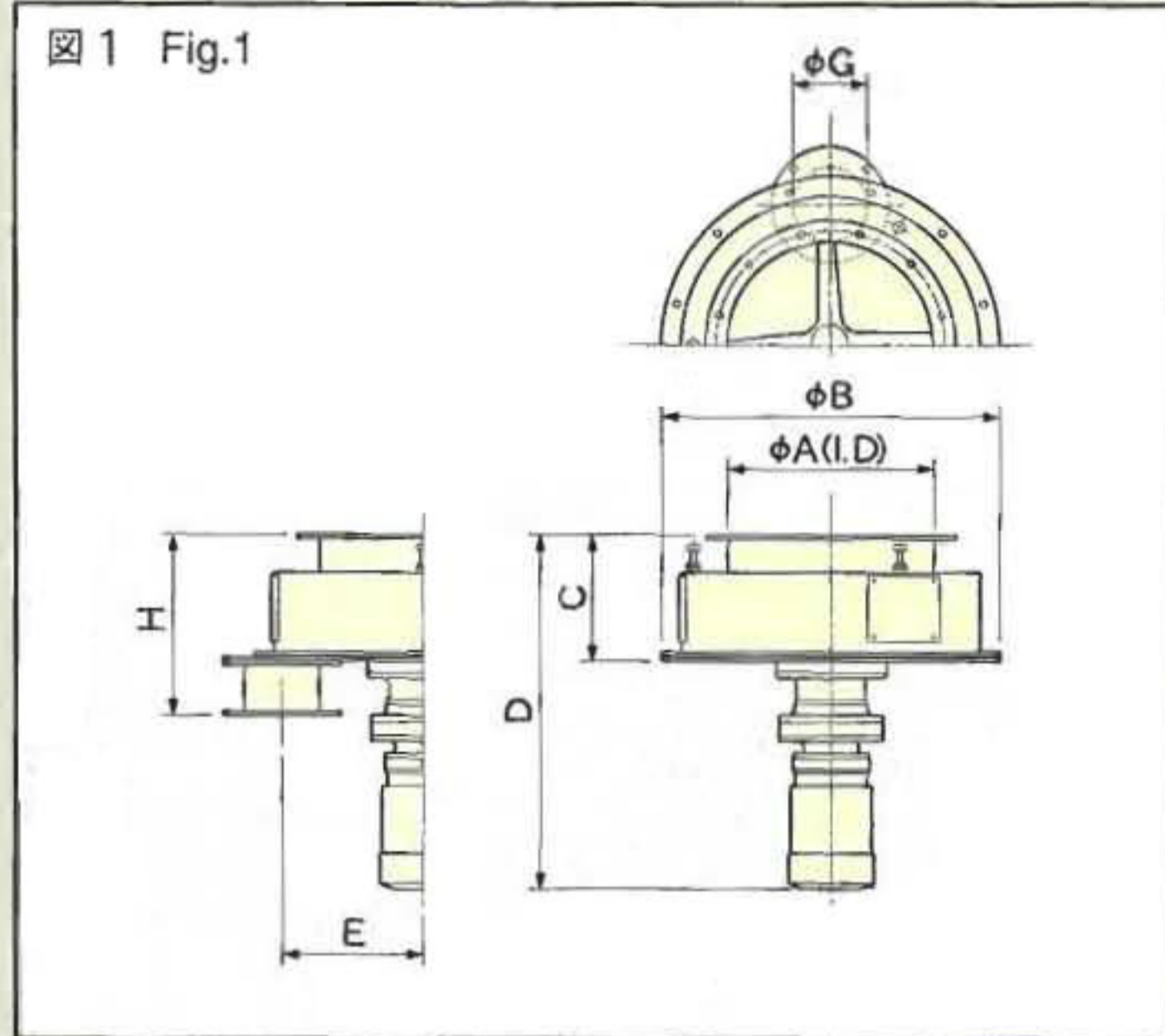

## 仕様 Specifications

型式 Model		CF-200		CF-300		CF-500		CF-700		CF-1000		CF-1200		CF-1400		CF-1600		CF-1800		CF-2000		CF-2400	
項目 Item		A	B	A	B	A	B	A	B	A	B	A	B	A	B	A	B	A	B	A	B	A	B
最大能力 Max. Capability (m <sup>3</sup> /h)	50Hz	0.13	0.66	0.38	0.89	0.92	2.4	4.9	13	10	20	13	29	18	35	20	38	27	48	30	59	40	86
	60Hz	0.15	0.80	0.46	1.1	1.1	2.9	5.9	15	12	24	16	35	22	42	24	46	32	58	36	71	48	104
最小能力 Min. Capability (m <sup>3</sup> /h)	50Hz	0.05	0.37	0.21	0.49	0.51	1.1	1.9	5.6	3.2	7.4	3.9	9.1	5.3	14	5.9	15	6.8	17	8.6	18	11	32
	60Hz	0.06	0.44	0.26	0.59	0.62	1.3	2.3	6.8	3.9	8.9	4.8	11	6.4	16	7.1	18	8.2	20	10	22	13	38
電動機(kW) Motor Capacity		0.04		0.2		0.4		0.4		1.5		2.2		3.7		3.7		5.5		7.5		7.5	
回転数(r/min) Rotation Speed	50Hz	8.1		5.3		6.3		5.3		4.5		4.2		3.6		3.1		2.8		2.6		2.1	
	60Hz	9.7		6.4		7.6		6.4		5.5		5.1		4.3		3.7		3.4		3.1		2.5	
寸 度 Dimensions (mm)	A	200	200	300	300	500	500	700	700	1000	1000	1200	1200	1400	1400	1600	1600	1800	1800	2000	2000	2400	2400
	B	330	410	492	552	766	826	1076	1176	1426	1516	1626	1776	1876	2026	2180	2330	2430	2580	2680	2830	3180	3380
	C	150	150	185	185	240	270	310	390	370	440	430	490	510	555	515	560	560	625	580	685	645	760
	D	315	315	519	519	608	638	693	773	941	1011	1074	1134	1229	1274	1261	1306	1402	1467	1484	1589	1646	1761
	E	130	150	205	230	296	311	415	438	578	600	680	714	790	824	910	940	1015.5	1050	1130	1160	1356	1396
	F	—	—	—	—	98	128	170	224	194	240	190	272	220	302	230	320	269	350	290	380	338	458
	G	96.6	133.8	109.3	159.2	180	180	275	314	314	350	350	410	380	450	389	470	410	498	450	579	498	629
	H	200	200	265	265	320	350	390	470	450	520	510	570	610	655	615	660	660	725	680	785	745	860
重量(kg) Weight		16	19	60	70	125	145	245	320	410	480	695	800	940	1100	1300	1450	1610	1790	1940	2180	2820	3150
外形図 External Diagram		図 1 Fig.1						図 2 Fig.2															

- 仕様は粉体の物性により変わる場合があります。
- 電動機およびD寸法は、能力・かさ密度・ホッパー形状などにより変わる場合があります。
- 排出口：標準は1カ所です。(2カ所以上取付も可能です。)
- 標準以外に特殊仕様も製作しています。
  - 材質 標準 SS400、SUS304
  - その他 SUS316、316L、チタン、ハステロイ樹脂コーティング等
- 水密構造
- 気密仕様 490.3kPa (5kg/cm<sup>2</sup>) 等
- 耐熱仕様 (粉体温度 700°C 等)
- 耐摩耗仕様 (回転羽根 他)
- 防爆仕様 (eG3、d2G4)
- サニタリー仕様
- 回転制御 (バイエル、ディスコ、インバータ等) 等
- CF-200は回転制御が標準です。
- 大型サークルフィーダ
- CF-2400を超える大型機も製作しています。ご相談下さい。

- Specifications may vary in accordance with the characteristics of the powder material.
- A motor and the dimension D may also vary in accordance with capability required, bulk density, or a hopper type.
- One exhaust port is provided as a standard feature. (Additional ports can be attached as required, e.g. two ports.)
- Additionally, special specification models are also available.
  - Standard materials : SS400, and SUS304
  - Optional materials : SUS316, 316L, titanium, hastelloy resin-coating, and etc.
- Watertight construction
- Airtight 490.3kPa (5kg/cm<sup>2</sup>) for example.
- Heat-resistant specifications (700°C of powder material temperature, etc.)
- Wear-resistant specifications (rotary vanes, etc.) and many more.
- Explosion-proof specifications
- Sanitary specifications.
- Revolution speed control optionally by Beier, disco, or inverter.
- CF-200 with revolution speed control unit as a standard.
- Large-sized Circle Feeder
- Equipment larger than CF-2400 is also available. Inquiries are invited.